

BFFD-03

Split Rooftop Bus A/C



Energy Saving



Safety



Light Weight



Comfortable



Recyclable



Intelligent

www.clingac.com



marketing@clingac.com



+86 371 85335504



Zhengzhou, Henan ,China

BFFD-03

Technical Data

Cooling Capacity(kcal/h)	18000
Heating Capacity(kcal/h)	/
Evaporator Air Flow(m ³ /h)	4000
Condenser Air Flow(m ³ /h)	5700
Fresh Air(m ³ /h)	1000
Size (mm) L*W*H	3335*1820*187
Power Consumption(24V)	<65A
Refrigerant	R134a
Appliable(m)	7-8
Compressor	VALEO TM31

- ✔ LFT-D structure
- ✔ Rubber and thermal insulation materials
- ✔ Noise level reduced more than 2dB
- ✔ Powerful cooling :Big margin design
- ✔ Patented CAN control
- ✔ Over 100,000 sets running globally since 2003



Drawing

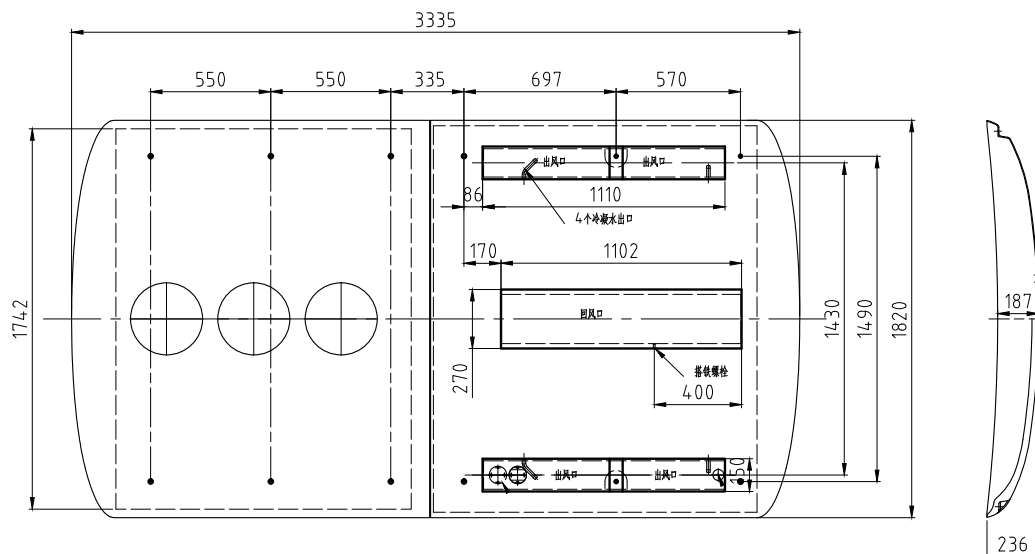

(Note: Size is for reference only)



Van



Double Decker Bus



City Bus



High Decker Bus



Intercity Bus



Shuttle Bus



Coach



School Bus

