

LEZHS-08

Back-mounted Bus A/C



Energy Saving



Safety



Light Weight



Comfortable



Recyclable



Intelligent

www.clingac.com

LEZHS-08



Technical Data

Cooling Capacity(kcal/h)	52000
Heating Capacity(kcal/h)	50000
Max Power Consumption(A)	103
Evaporator Airflow(m ³ /h)	10000(8pcs)
Condenser Airflow(m ³ /h)	12000(6pcs)
Compressor Displacement(CC)	/
Refrigerant	R410A
Size (mm) L*W*H	2000*750*1167
Application(M)	10-12

- High Efficiency**
 The upper and lower double-layer air supply is evenly distributed.
- Powerful Cooling**
 Large cooling capacity.
- LFT-D Structure**
 ultralight, consistent, recyclable and rigid.
- Compact & Simple**
 Compact structure, small volume and easy installation.
- Patented CAN Control**
 modular design, digital communication.



Drawing

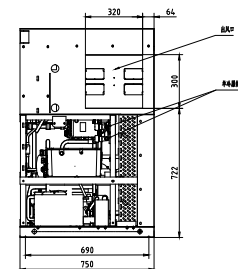
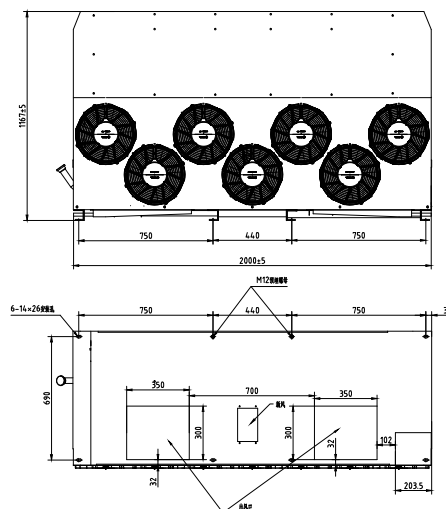

Van



Double Decker



City Bus



Intercity Bus



Coach



School Bus