

SDD-03

Compact Rooftop Bus A/C



Energy Saving



Safety



Light Weight



Comfortable



Recyclable



CAN system *

www.clingac.com



marketing@clingac.com



+86 187 3603 2501



Zhengzhou, Henan, China

SDD-03



Technical Data

Cooling Capacity(kcal/h)	22000
Max Power Consumption (A)	75
Evaporator Airflow(m ³ /h)	4000(4pcs)
Condenser Airflow(m ³ /h)	6000(3pcs)
Compressor Displacement(CC)	400
Refrigerant	R134a
Weight(kg)	156
Size (mm) L*W*H	2500*2000*220
Application(m)	6-7m

- ✔ LFT-D structure: ultralight, recyclable
- ✔ Thermal insulation materials: anticorrosive, odorless and flame-retardant
- ✔ V type micro-channel heat exchanger optional: heat exchange surface increased 20%, cooling capacity 15% more
- ✔ Compact unit: 20% reduction in weight, heat exchange efficiency improved 20%, refrigerants charged 50% less



Drawing

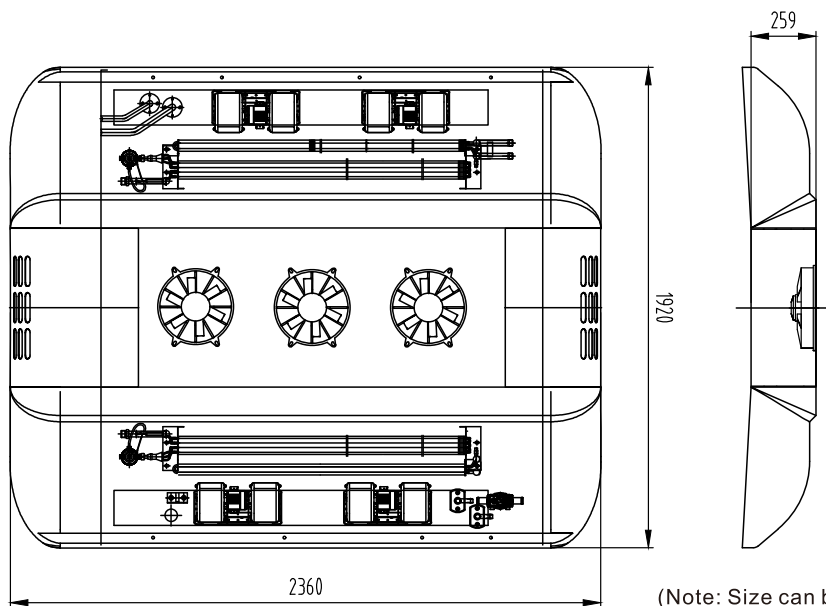

(Note: Size can be adjusted for different scenes)



Van



Double Decker Bus



City Bus



High Decker Bus



Intercity Bus



Shuttle Bus



Coach



School Bus