

EDDR-04

Independent Battery Thermal Management



Energy Saving



Safety



Light Weight



Comfortable



Recyclable



Intelligent

www.clingac.com



marketing@clingac.com



+86 371 85335504



Zhengzhou, Henan ,China

EDDR-04



Technical Data

Cooling Capacity	13kW
HP Power Supply	DC400V-DC750V
LP Power Supply	DC24V(18V-30V)
Weight (kg)	90
Size (mm) LxWxH	1300*1920*256
Control Power	DC24V on/off signal
LP Power Source	DC-DC(standard configuration)
Pump	As per customer requirement
Refrigerant	R407C
Coolant	50%VV Ethylene glycol aqueous solution
Pipe	As per customer requirement
Protection Level	IP54

- All DC inverter compressor features high efficiency and energy saving.
- PID variable frequency control and condenser fan PWM stepless speed regulation provide constant temperature environment for battery.
- EMC performance meets the level III of the national standard to avoid harm to personnel and equipment caused by electromagnetic radiation.



Drawing

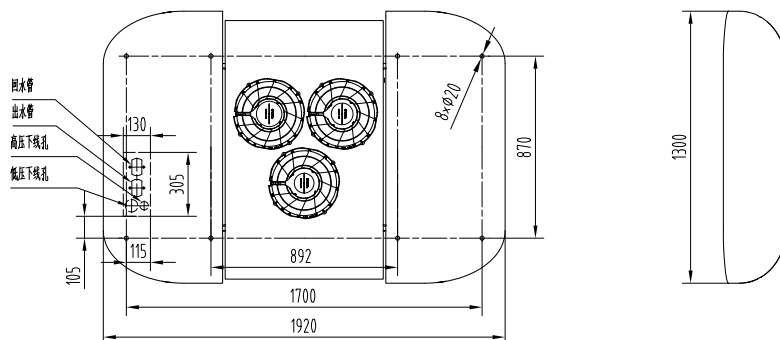

(Note: Size is for reference only)



Van



Double Decker Bus



City Bus



High Decker Bus



Intercity Bus



Shuttle Bus



Coach



School Bus