

# XDD-02

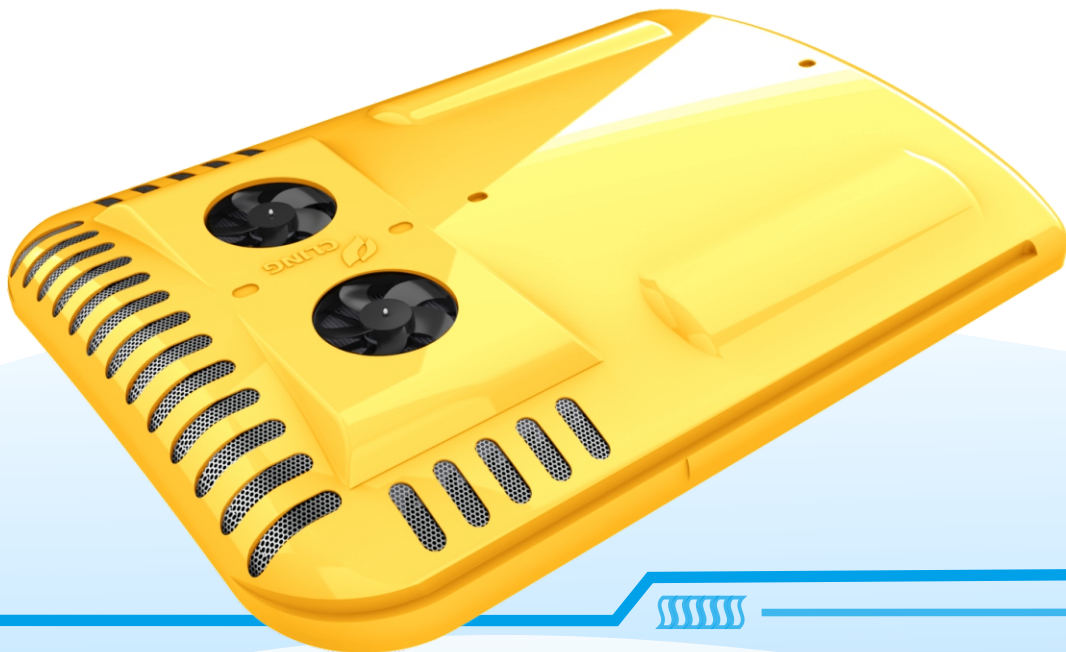

## Compact Rooftop School Bus A/C



Lighter



Cooling



Heating



Ventilation



Fresh air



Low noise



Fast repair



Profile flip structure



Standard fixing bracket

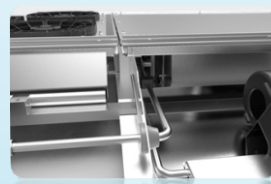

Glue-free structure



NVH noise test

# XDD-02



## Technical Data

Cooling Capacity(kcal/h)	16000
Max Power Consumption(A)	55
Evaporator Airflow(m <sup>3</sup> /h)	3440
Condenser Airflow(m <sup>3</sup> /h)	4000
Compressor Displacement(CC)	310
Refrigerant	R134a
Weight(kg)	110
Size (mm) L*W*H	2090*1640*220
Application(M)	6-8

- Highly efficient microchannel heat transfer;
- EMC performance meets the second level of the GB, avoiding electromagnetic radiation harmful to personnel and equipment;
- Environmentally adaptive energy-saving speed-regulating fans;
- Compact size, lightweighting, elegant appearance, excellent cost performance.



## Installation Drawing

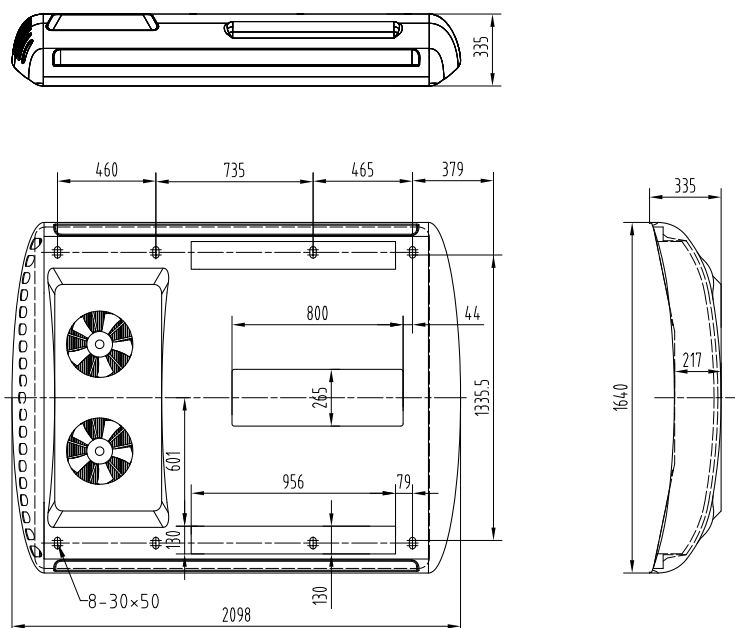

(Note: Size is for reference only)